



TOYOTA

Move your world

REINVENT YOUR HORIZON



**NEW COROLLA CROSS
HYBRID ELECTRIC**



BEYOND ZERO



Drive beyond expectations with the New Corolla Cross Hybrid Electric, designed to reduce emissions with zero compromise on style, comfort, and performance.

REINVENT YOUR HORIZON

4TH GENERATION TOYOTA HYBRID ELECTRIC SYSTEM

Our advanced 4th Generation Hybrid System seamlessly blends electric and petrol power, ensuring a responsive and efficient driving experience that keeps you moving forward.

**EFFICIENT
PETROL ENGINE**



**POWERFUL
ELECTRIC MOTORS**



**HIGH-PERFORMANCE
HYBRID ELECTRIC BATTERY**



SELF-CHARGING AS YOU DRIVE

**Battery
powers car**



**Battery
is charged**



**Dual power
for quicker
acceleration**



**Braking
charges battery**



Engine auto off

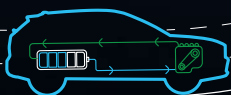
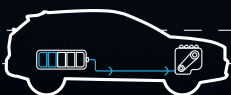

START/LOW SPEED
Only the motor powers the whole car with electricity from the Hybrid Electric battery.*

NORMAL DRIVING
The engine and motor power the car together while the Hybrid Electric battery is charged.

HARD ACCELERATION
Petrol engine and electric motor provide maximum power together with supplemental electrical power from the HEV battery to the motor.

BRAKING
The energy that is generated from braking charges the battery.

STOPPED
The engine goes off to avoid wasting fuel.

* Toyota Hybrid Electric System will charge the Hybrid Electric battery automatically depending on the driving condition, weather and Hybrid Electric battery state of charge.

HYBRID

The Toyota Hybrid Electric System delivers maximum efficiency, advanced tech, and a greener future—all in one.

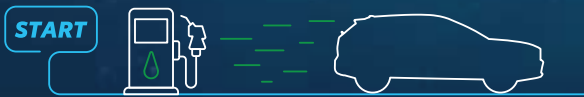

1 High Efficiency

Save on fuel costs with Toyota's Hybrid Electric System, which reduces consumption by using the electric motor at low speeds.



4 Regenerative Braking

Toyota's self-charging hybrid system captures energy from braking to recharge the battery—no plug-in needed—keeping you powered without wasting energy.



2 Year-round Reliability

Drive with confidence, backed by an 8-year unlimited mileage warranty on key hybrid components, ensuring your vehicle stays reliable for years to come. (Optional extension available for years 9 and 10.)

4TH GENERATION
HYBRID ELECTRIC
BATTERY



5 Intelligent Technology

The 4th Generation Hybrid Electric System features improved battery longevity, efficient air filtration, and advanced cooling for superior performance and durability.



3 Better Emissions

Corolla Cross Hybrid Electric CO₂ Emissions: **98 g/km**

Toyota's hybrid system helps create a cleaner, more sustainable future by using less petrol and reducing your carbon footprint.



6 Dual Power

Experience the best of both worlds—electric and petrol power, working together for improved performance, with a lower centre of gravity for better handling and a more stable, comfortable ride.



Built to elevate every drive, the New Corolla Cross Hybrid Electric offers a smooth, responsive performance that transforms everyday journeys into exceptional ones.

REINVENT YOUR JOURNEY



1.8L DOHC DUAL VVT-i ENGINE WITH HEV SYSTEM

Exclusively engineered for reduced friction, improved heat management, and outstanding fuel efficiency, the 1.8L Hybrid System delivers 23.3km/L fuel economy. Its compact size and lightweight design allow it to seamlessly fit the new platform, maintaining optimum engine output and a quiet cabin experience.



E-CVT

Expertly designed to give you higher fuel efficiency, greater driving performance and reduced cabin noise.



EV MODE & DRIVE MODE SWITCH

SPORT MODE offers more responsive acceleration while ECO MODE maximises fuel efficiency. EV MODE lets the electric motor take full control for silent drives with zero emissions.

1.8L DOHC DUAL VVT-i ENGINE

Balances responsive acceleration and higher engine output along with improved combustion efficiency to deliver superior fuel economy.

139ps

Max. Output

172Nm

Max. Torque



7-SPEED CVT WITH SEQUENTIAL SHIFTMATIC

Incorporates a new cooperative control with the electronically-controlled throttle for increased drivability, quietness and fuel economy.



18° APPROACH ANGLE

Confidently take on rough urban roads with a big approach angle that easily handles large speed bumps.



BEST-IN-CLASS TURNING RADIUS

Move around town easily with the best-in-class turning radius of 5.2m.

REINVENT YOUR IMAGE

Make a lasting impression with the bold front grille design. BI-LED headlamps and LED Daytime Running Lights extend to the edges, delivering a wide and confident look.



LED REAR LAMPS WITH LIGHT CURTAIN DESIGN

Tail lamps with a unique light curtain design offer a crisp, uniform glow, enhancing both visibility and Corolla Cross Hybrid Electric's modern aesthetic.



ROOF RAILS

A small addition to the roof for a big boost to style. Can withstand up to 70kg of loading weight.



AUTOMATIC RAIN SENSORS

Detects rain drops on your windshield and automatically activates the wipers.

REINVENT YOUR SPACE

Experience true comfort. Inside, spacious design and refined finishes create a driving environment built around your needs, enhancing every journey.



DUAL-ZONE AIR-CONDITIONING

The Dual-zone Auto Air-conditioning also allows the driver and front passenger to set independent temperatures to suit their own comfort levels.



ELECTRONIC PARKING BRAKE

The previous foot pedal brake is replaced with an electronic parking brake (EPB), allowing you to hold the brakes with the touch of a button and automatically release when you accelerate, offering enhanced convenience and ease of use.



12.3" COLOUR MULTI-INFORMATION DISPLAY (MID)

Designed for maximum visibility, the MID provides important vehicle information at a glance and is customisable with 4 layout designs and 3 styles per design. It also changes color when you switch between SPORT MODE and ECO MODE.





DRIVER SEAT WITH 8-WAY POWER ADJUSTER

With the push of a button (or two), the driver can change the seat's position for maximum comfort.

CENTRE CONSOLE WITH SLIDING ARMREST

The centre console has been made wider for an enhanced appearance, while the sliding armrest increases the occupant's comfort regardless of physique.



REAR AIR-CONDITIONING VENT

Not to forget the rear seat passengers, whose comfort is also conveniently provided for.

REAR SEATS WITH 6° RECLINE ANGLE

Comfort doesn't just come from the improved cushion material and optimised armrest size. The recline angle of 6° supports a more comfortable posture.

REINVENT YOUR ASSURANCE

Crafted for your peace of mind, this vehicle incorporates innovative safety technologies that ensure every journey is secure. Navigate the roads with cutting-edge features designed to prioritise your protection.



360-T ADVANCED

It's all about Trust & Technology by Toyota

SAFE-T Trust for smoother journeys ahead



3D PANORAMIC VIEW MONITOR (PVM)

Get a detailed 360° view of your vehicle for manoeuvring in tight spaces.



BLIND SPOT MONITOR (BSM) WITH REAR CROSS TRAFFIC ALERT (RCTA)

Detects and alerts you to vehicles that may not be visible to you when changing lanes or reversing.



FRONT & REAR DVR (With Smartphone Connectivity)

Convenient access and monitoring via Toyota DVR app. (Rear DVR available as an optional accessory.)



7 SRS AIRBAGS

Driver, front passenger, side, curtain and driver's knee airbags provide complete protection for the driver and passengers in the event of a collision.

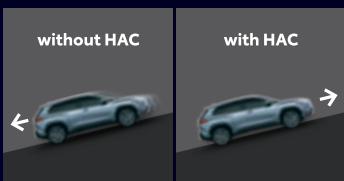

HILL-START ASSIST CONTROL (HAC)

Sustains brake pressure for 3 seconds to prevent the vehicle from rolling backwards on an incline.



PARKING SUPPORT BRAKE (PKSB)*

Helps prevent collisions at low speeds by controlling brakes and drive force when detecting objects in front, behind or vehicles crossing from the rear.



TYRE PRESSURE WARNING SYSTEM (TPWS)

Notifies you when tyre pressure is below an acceptable level, indirectly helping you maintain optimum fuel efficiency at all times.



8 PARKING SENSORS

Have a little extra peace of mind with 4 ultrasonic sensors in the front and 4 at the back.

SAFE-T Trust for smoother journeys ahead



PRE-COLLISION SYSTEM (PCS)*

Avoids or mitigates frontal collisions by alerting the driver and automatically applying the brakes when there is a risk of collision.



LANE DEPARTURE ALERT (LDA)*

Alerts and assists when you are out of the lane unintentionally. Less swaying, smoother driving.



DYNAMIC RADAR CRUISE CONTROL (DRCC) FOR ALL SPEEDS*

At any speed, it maintains a safe distance with the preceding vehicle and brakes automatically when the car ahead slows down.



LANE TRACING ASSIST (LTA) FOR ALL SPEEDS*

Keeps the vehicle centred either by detecting the lane or the preceding vehicle at any speed.



AUTOMATIC HIGH BEAM (AHB)*

Automatically switches between high beam and low beam as needed to provide maximum road visibility.



*Driver remains solely responsible at all times for safe driving.

CONNECTIVI-T

Technology at your command



10.1" DISPLAY AUDIO WITH WIRELESS AACP CONNECTIVITY*

Connect your smartphone wirelessly to the multimedia display for calls, music, and navigation. With Apple CarPlay® and Android Auto™, enjoy a convenient and personalised driving experience.



WIRELESS CHARGER

Offers convenient charging for Qi** standard-compliant devices, without the use of a cable.



VEHICLE TELEMATICS SYSTEM (VTS)

An integrated system that monitors and shares your vehicle's real-time location through a mobile app.



REMOTE ENGINE START

Our Vehicle Telematics System (VTS), enhanced with the Toyota MY app, lets you start your car remotely so the cabin is perfectly cooled before you even step inside.

GUARAN-T

Total peace of mind



5 years vehicle warranty from the date of first registration with unlimited mileage. Terms and conditions apply.



8 years warranty from the date of first registration with unlimited mileage covering the Hybrid Electric Vehicle (HEV) battery, inverter and power management control ECU. Optionally, this Hybrid Electric warranty can be extended for another 2 years (9th & 10th year). Terms and conditions apply.

*Android Auto™ will be available when the service is officially launched in Malaysia. Functions may vary depending on smartphone model.

**International standard for wireless charging developed by Wireless Power Consortium.

REINVENT YOUR EVERYDAY

Maximise practicality with generous boot space and versatile folding seats. The rear view mirror ensures clear visibility, making every drive a breeze.



SPACIOUS BOOT SPACE

Enjoy generous luggage space which fits in various types of loads. For the Corolla Cross Hybrid Electric, the repositioning of the Hybrid Electric battery allows the boot space to be uncompromised.



ELECTROCHROMIC REAR VIEW MIRROR

When the rear view mirror detects a glare from the car at the back, it darkens so the glare does not affect your drive. Only for Hybrid Electric variant.



60:40 SPLIT-FOLDING SEATS

The rear seats can be folded down to help you fit long items into the boot.

KICK-SENSOR POWER BACK DOOR

Automatically open and close the back door by performing a kick motion under the rear bumper.



SECURITY



SECURITY & SOLAR FILM

Makes glass more resistant to prevent break-ins, while also protecting occupants from harmful rays and reducing heat build-up in the car.

CHOICE OF COLOURS



Celestite Grey Metallic (1K3)
(Only available for HEV variant.)



Silver Metallic (1D4)



Red Mica Metallic (3R3)



Platinum White Pearl (089)



Dark Turquoise (B88)

NEW

SPECIFICATIONS

POWERTRAIN		1.8 HEV	1.8V
Type		4-cylinder, In-line, 16-Valve DOHC with VVT-i	
Bore x Stroke	mm	80.5 x 88.3	
Max. Output	kW (PS) / rpm	72 (98) / 5,200	103 (139) / 6,400
Max. Torque	Nm / rpm	142 / 3,600	172 / 4,000
Transmission		E-CVT	7-speed CVT with Sequential Shiftmatic
MOTOR GENERATOR			
Max. Output	kW	53	-
Max. Torque	Nm	163	-
HYBRID ELECTRIC BATTERY			
Type		Nickel Metal Hydride Battery	-
Voltage	V	201.6	-
Capacity	Amr	6.5	-
CHASSIS			
Suspension	Front / Rear	MacPherson Strut with Stabiliser / Torsion Beam with Stabiliser	
Brakes	Front / Rear	Ventilated Disc / Solid Disc	
Tyres & Rims		225/50 R18, Alloy	
Spare Tyre & Rim		T155/70D17	
DIMENSIONS			
Minimum Turning Radius	m	5.2	
Min. Running Ground Clearance	mm	161	
Kerb Weight	kg	1,430	1,405
Fuel Tank Capacity	litre	36	47
EXTERIOR			
Headlamps	Type	Bi-LED with Sequential LED Turn Signal Lamps	
	Daytime Running Lights (DRL)	LED	
	Levelling	Manual	
Front & Rear Fog Lamps		LED	
Front Wiper		Automatic with Rain Sensor	
Front Windshield Glass		Acoustic Type	
Rear Lamps		LED with Light Curtain	
Radiator Grille		Body Color Paint Grille	
Wing Mirrors		Power-adjustable, Auto Fold with Reverse Link, Signal Lamps & Blind Spot Monitor (BSM)	
Power Back Door		With Kick Sensor	
Roof Rails		With	

DIMENSIONS

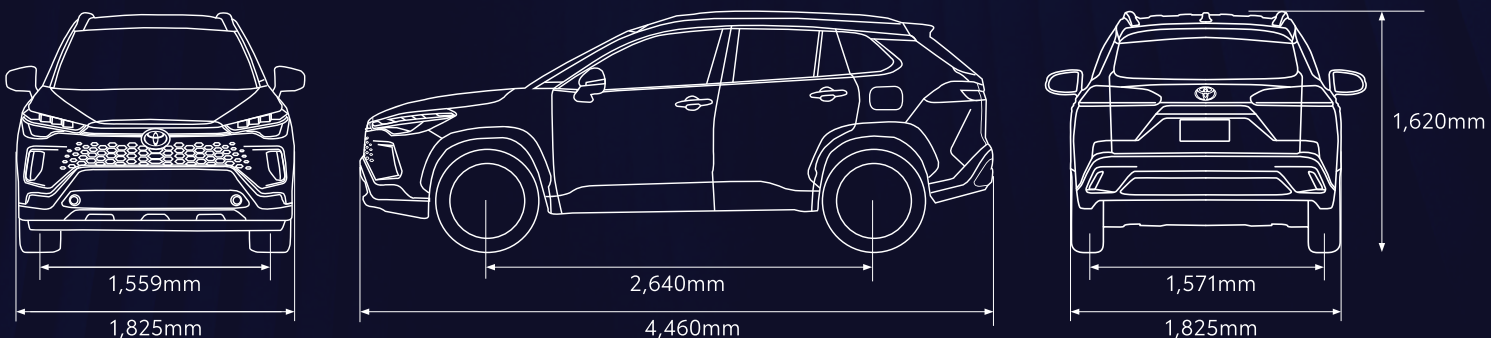

INTERIOR		1.8 HEV	1.8V
Interior Colour & Trim		Black	
Seats Material		Black Leather with Brown Accent Design	
Smart Entry & Start System		With	
Gear Shift Lever		Leather	
Steering Wheel	Type	3-spoke Leather with Tilt & Telescopic Adjustable	
	Switches	Audio, MID, Telephone, Adaptive Cruise Control & Lane Tracing Assist	
Drive Mode		POWER / ECO / NORMAL / EV	Without
Multi-Information Display (MID)		12.3"	4.2"
Air-conditioning		Automatic Dual-zone Climate Control	Automatic Single Zone Climate Control
Inside Rear View Mirror		Electrochromic Mirror	Day & Night
Illumination System		With (Front Door, Door Switch, Cup Holder & Center Tray)	
Electric Parking Brake		With	
Front Digital Video Recorder (DVR)			
3D Panoramic View Monitor (PVM)		With	
Audio	Type	10.1" Touch Screen Display Audio, Wireless Apple CarPlay & Android Auto™, USB & Bluetooth®	
	Speakers	6	
Front Seat	Driver Seat	With 8-way Power Adjuster	
	Front Passenger Seat	Manual Adjust	
	Front Armrest	With Sliding Armrest	
	Front Cup Holders	With	
Rear Seat	Type	60:40 Split-folding with Rear Reclining (1 Step)	
	Rear Armrest	With Cupholders	
Rear Air Ventilations		With	
Tonneau Cover		With Roll-up Type	
RFID		With	
Carpet Mat		with HEV Design	With
SAFETY			
Toyota Safety Sense (TSS)		With	
Pre-collision System (PCS)		With	
Lane Departure Alert (LDA) with Steering Assist		With	
Dynamic Radar Cruise Control (DRCC)		With	
Lane Tracing Assist (LTA)		With	
Automatic High Beam (AHB)		With	
Blind Spot Monitor (BSM)		With	
Rear Cross Traffic Alert (RCTA)		With	
Parking Support Brake (PKSB)		With	
Vehicle Stability Control (VSC), Traction Control (TRC), Hill-start Assist Control (HAC), Emergency Brake Signal (EBS), Drive Start Control, Tyre Pressure Warning System (TPWS), Anti-lock Braking System (ABS), Electronic Brake-force Distribution (EBD) and Brake Assist (BA)		With	
Hybrid Regenerative Braking		With	Without
Parking Sensors		With (Front x4 & Rear x4)	
SRS Airbags		7 Airbags (Fronts, Front Sides, Curtains & Driver Knee)	
Seat Belts	Front / Rear	3-point ELR x 2 with Pretensioner and Force Limiter / 3-point ELR x 3	
ISOFIX		With (Rear Only)	

SECURITY	1.8 HEV	1.8V
Security System	Immobiliser, Alarm & Speed Auto Door Lock	
Toyota Premium Security & Solar Film	With	
Vehicle Telematics System (VTS)	Connectivity with Mobile Apps with Remote Engine Start	
OPTIONAL		
Rear Digital Video Recorder (DVR)	Optional	

- UMW Toyota Motor reserves the right to alter any details of specifications and equipment without notice.
- Details of specifications and equipment are also subject to change to suit local conditions and requirements.
- Vehicle and specifications in this catalogue may vary from models available locally.
- Vehicle body and accessory colours might differ slightly from the printed photos in this catalogue.
- All images used are for illustrative purposes.



5 years vehicle warranty from the date of first registration with unlimited mileage. Terms and conditions apply.



8 years warranty from the date of first registration with unlimited mileage covering the Hybrid Electric Vehicle (HEV) battery, inverter and power management control ECU. Optionally, this Hybrid Electric warranty can be extended for another 2 years (9th & 10th year). Terms and conditions apply.



The Corolla Cross has been awarded a 5-star ASEAN NCAP safety rating.



Energy Efficient Vehicle